

Spare parts list Hydraulic breakers

| | Valid from serial number |
|-----------|--------------------------|
| MB 750 | 50 |
| MB 750 DP | 50 |

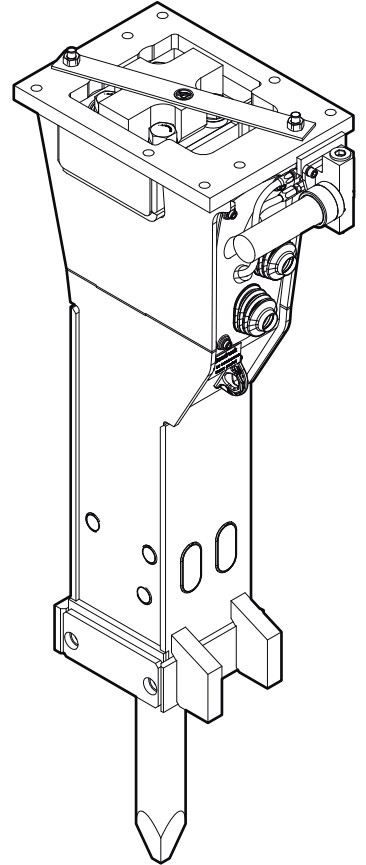

Contents

| | |
|---|----|
| General information..... | 5 |
| Spare parts list..... | 6 |
| Hydraulic breaker MB 750..... | 6 |
| Hydraulic breaker MB 750 DustProtector..... | 8 |
| Percussion unit part 1: cylinder cover..... | 10 |
| Percussion unit part 2: cylinder..... | 12 |
| Percussion unit part 3: lower breaker part..... | 14 |
| Connecting kit for ContiLube® II..... | 16 |
| Optional parts..... | 18 |
| Tightening torques..... | 19 |
| Working tools..... | 20 |
| MB 750..... | 20 |
| MB 750 DustProtector..... | 21 |
| Accessories..... | 22 |
| Hydraulic hoses..... | 22 |
| Optional equipment..... | 22 |
| Kits..... | 23 |
| Label kit MB 750..... | 23 |
| Label kit MB 750 DustProtector..... | 24 |
| Seal kit..... | 25 |
| Plastic parts kit..... | 25 |
| Tensioning bolt kit..... | 25 |
| DustProtector kit..... | 26 |
| Noise protection kit..... | 26 |
| Lower breaker part kit..... | 26 |
| Lower breaker part kit DustProtector..... | 27 |
| Dimensions..... | 28 |
| Dimensions MB 750..... | 28 |
| Dimensions MB 750 DustProtector..... | 29 |

General information

This spare parts list applies to the following:

| Part number | Description |
|--------------|--|
| 3363 1007 39 | Hydraulic breaker MB 750 |
| 3363 1046 81 | Hydraulic breaker MB 750 DustProtector |

Use only authorized parts. Any damage or malfunction caused by the use of unauthorized parts is not covered by Warranty or Product Liability. Any unauthorized use or copying of the contents or any part thereof is prohibited. This applies in particular to trademarks, model denominations, part numbers, and drawings.

Instructions for use

This spare parts list contains no safety regulations and is merely intended to assist in the ordering of spare parts.

For information on operating, servicing, or repairing, the relevant Safety and operating instructions must be consulted at all costs.

Please observe the safety instructions listed in the relevant Safety and operating instructions!

Instructions of ordering

It is essential to indicate the serial number of the hydraulic attachment when ordering spare parts!

Please note the full identification number of your hydraulic attachment. This code can be found on the cylinder.

Determine the quantity of individual parts which are required and need to be ordered. The order must indicate the following details:

- full identification code of the hydraulic attachment
- required quantity
- part number
- description

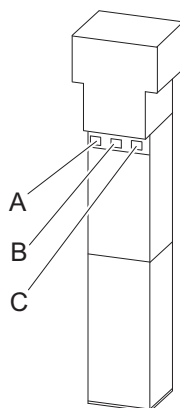

- A. Cylinder number
- B. Type
- C. Serial number

Spare parts list

Hydraulic breaker MB 750

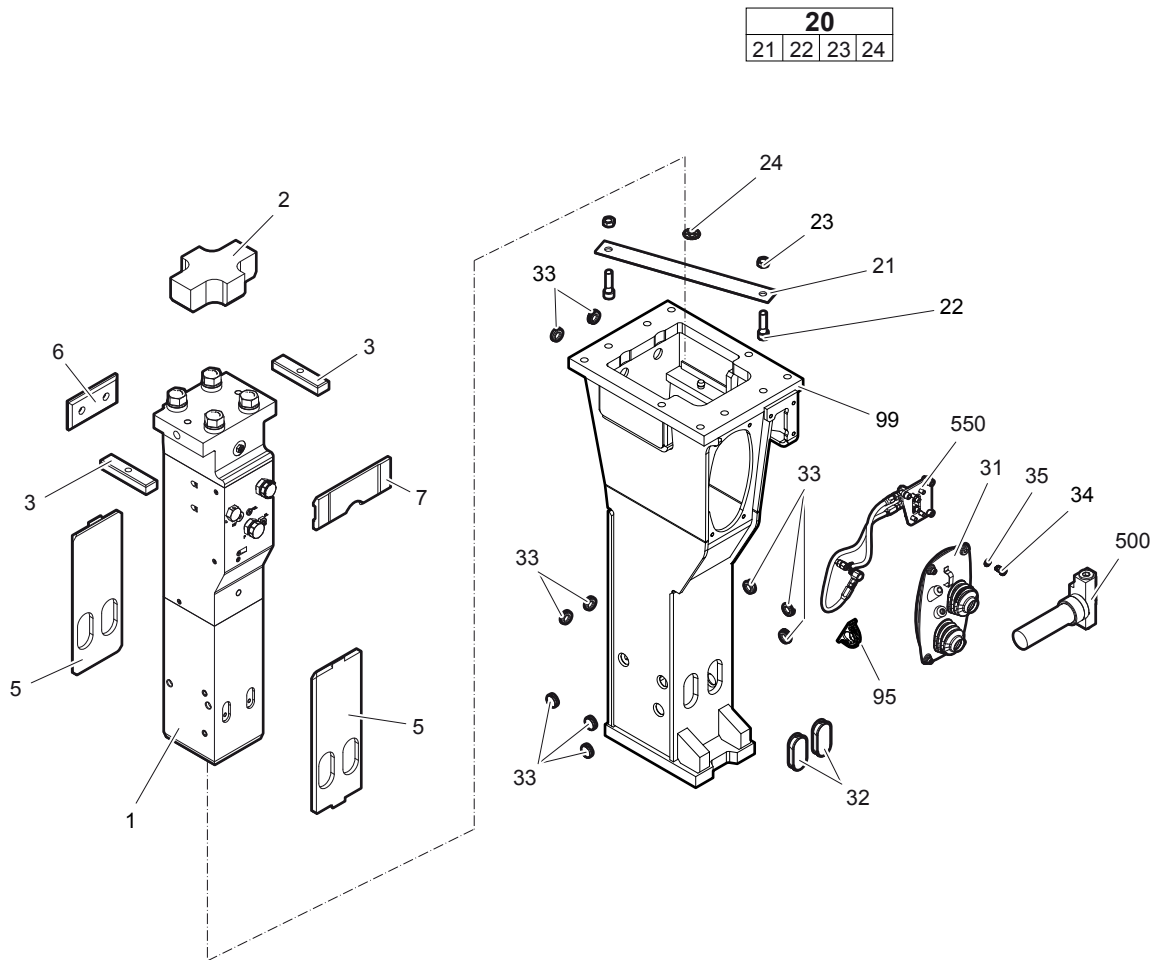

| No. | Description | Remark | Quantity | Part number |
|------------------|---|---|----------|--------------|
| 1 | Percussion unit | see separate chapter | 1 | - |
| 2 | Elastic pad | | 1 | 3363 0928 57 |
| 3 | Shock absorber | | 2 | 3361 8522 37 |
| 5 | Guide plate | | 2 | 3363 1007 37 |
| 6 | Guide plate | | 1 | 3363 0842 31 |
| 7 | Guide plate | | 1 | 3363 0928 61 |
| 20(21-24) | Transport safety device complete | | 1 | 3363 0837 31 |
| 21 | Transport safety device | | 1 | - |
| 22 | Allen screw | | 2 | 3360 0267 86 |
| 23 | Nut | | 2 | 3360 1032 51 |
| 24 | Label transport safety device | | 1 | 3363 0918 72 |
| 31 | Cover | | 1 | 3363 0928 63 |
| 32 | Plug | | 2 | 3363 0860 11 |
| 33 | Plug | | 10 | 3362 2678 97 |
| 34 | Allen screw | | 4 | 3360 1007 91 |
| 35 | Pair of lock washers | | 4 | 3361 8505 96 |
| 95 | Lifting eye | professional welding process necessary | 1 | 3363 1119 93 |
| 99 | Breaker box | | 1 | 3363 1032 24 |
| 500 | ContiLube® II | see separate <i>Safety and operating instructions</i> | 1 | 3363 0671 23 |
| 550 | Connecting kit for ContiLube® II | see separate chapter | 1 | 3363 0914 76 |

Hydraulic breaker MB 750 DustProtector

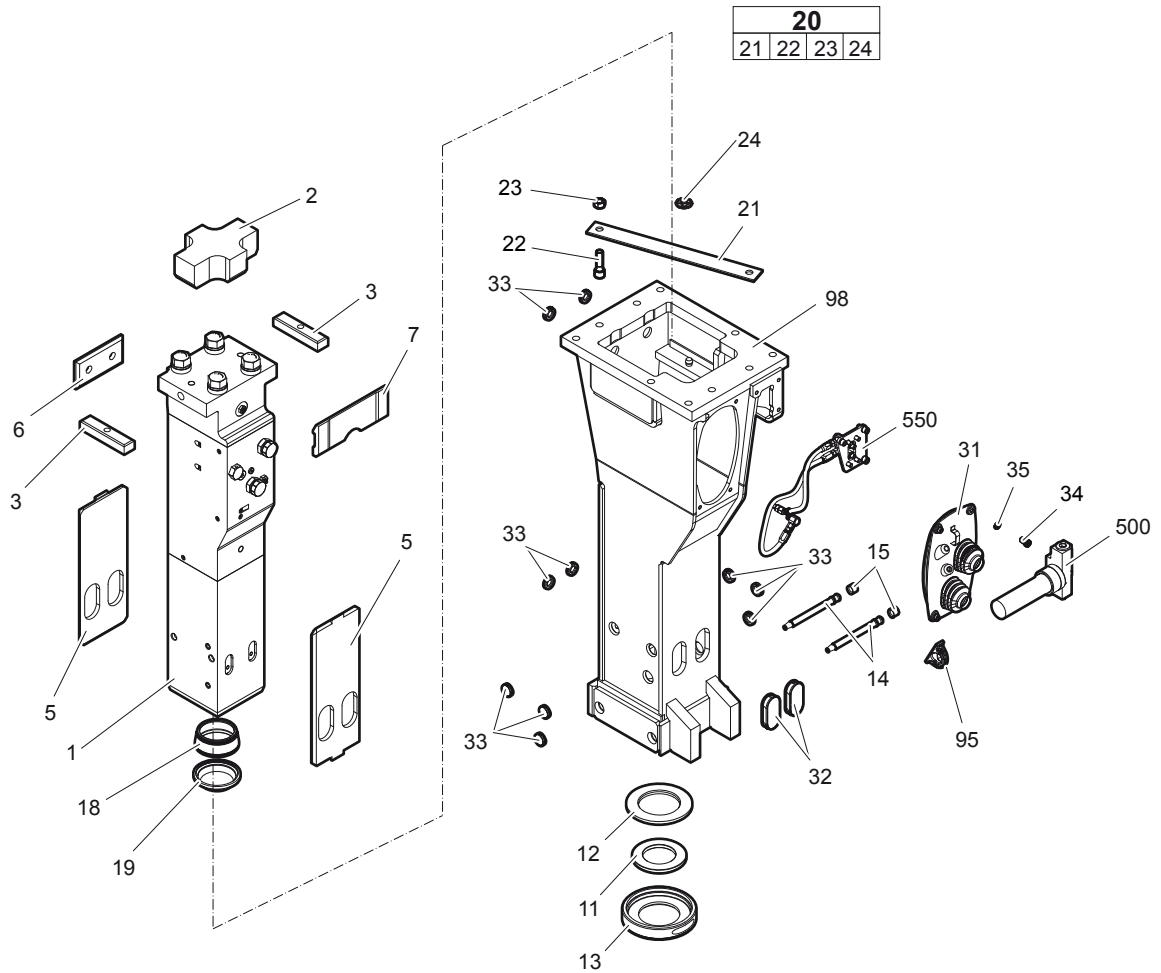

| No. | Description | Remark | Quantity | Part number |
|------------------|---|---|----------|--------------|
| 1 | Percussion unit | see separate chapter | 1 | - |
| 2 | Elastic pad | | 1 | 3363 0928 57 |
| 3 | Shock absorber | | 2 | 3361 8522 37 |
| 5 | Guide plate | | 2 | 3363 1007 37 |
| 6 | Guide plate | | 1 | 3363 0842 31 |
| 7 | Guide plate | | 1 | 3363 0928 61 |
| 11 | Floating ring | tribolid steel see chapter <i>Optional parts</i> | 1 | 3363 0706 58 |
| 12 | Counter ring | | 1 | 3363 0352 07 |
| 13 | Guide ring | | 1 | 3363 0352 05 |
| 14 | Bolt | | 2 | 3363 0913 65 |
| 15 | Locking bush | | 2 | 3361 8543 63 |
| 18 | Base for wiper | | 1 | 3363 1047 83 |
| 19 | Wiper | | 1 | 3363 0343 94 |
| 20(21-24) | Transport safety device complete | | 1 | 3363 0837 31 |
| 21 | Transport safety device | | 1 | - |
| 22 | Allen screw | | 2 | 3360 0267 86 |
| 23 | Nut | | 2 | 3360 1032 51 |
| 24 | Label transport safety device | | 1 | 3363 0918 72 |
| 31 | Cover | | 1 | 3363 0928 63 |
| 32 | Plug | | 2 | 3363 0860 11 |
| 33 | Plug | | 10 | 3362 2678 97 |
| 34 | Allen screw | | 4 | 3360 1007 91 |
| 35 | Pair of lock washers | | 4 | 3361 8505 96 |
| 95 | Lifting eye | professional welding process necessary | 1 | 3363 1119 93 |
| 98 | Breaker box | | 1 | 3363 1032 23 |
| 500 | ContiLube® II | see separate <i>Safety and operating instructions</i> | 1 | 3363 0671 23 |
| 550 | Connecting kit for ContiLube® II | see separate chapter | 1 | 3363 0914 76 |

Percussion unit part 1: cylinder cover

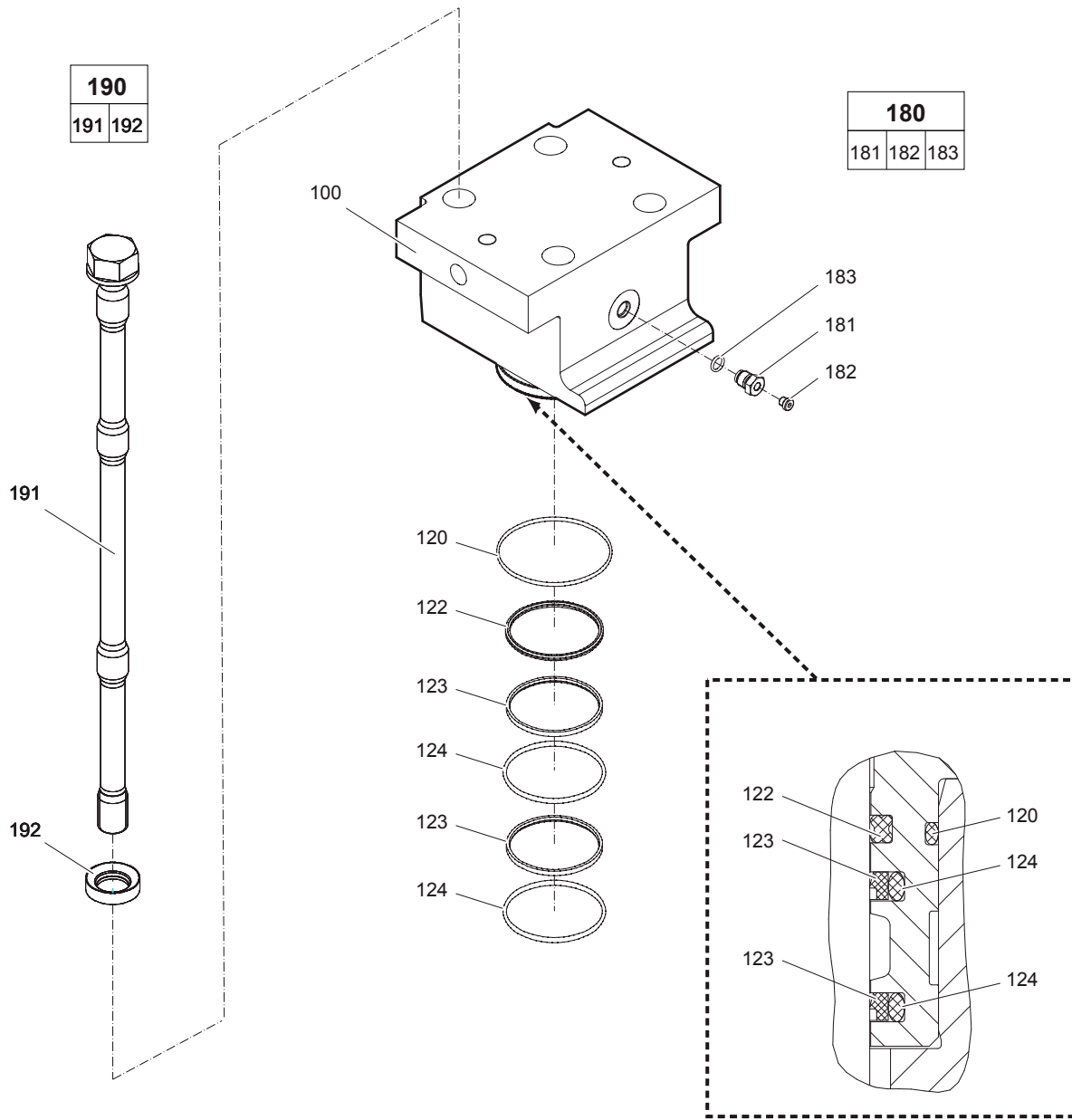

| No. | Description | Remark | Quantity | Part number |
|---------------------|---------------------------------|--------|----------|--------------|
| 100 | Cylinder cover | | 1 | 3363 0917 04 |
| 120 | O-ring | | 1 | 3360 3146 64 |
| 122 | Seal | | 1 | 3363 0917 10 |
| 123 | Seal | | 2 | 3363 0917 08 |
| 124 | O-ring | | 2 | 3363 0917 09 |
| 180(181-183) | Filling valve complete | | 1 | 3363 0872 86 |
| 181 | Filling valve | | 1 | - |
| 182 | Threaded plug | | 1 | 3360 4784 26 |
| 183 | O-ring | | 1 | 3360 1751 25 |
| 190(191-192) | Tensioning bolt complete | | 4 | 3363 0917 02 |
| 191 | Tensioning bolt | | 1 | 3363 0928 73 |
| 192 | Washer | | 1 | 3363 0936 45 |

Percussion unit part 2: cylinder

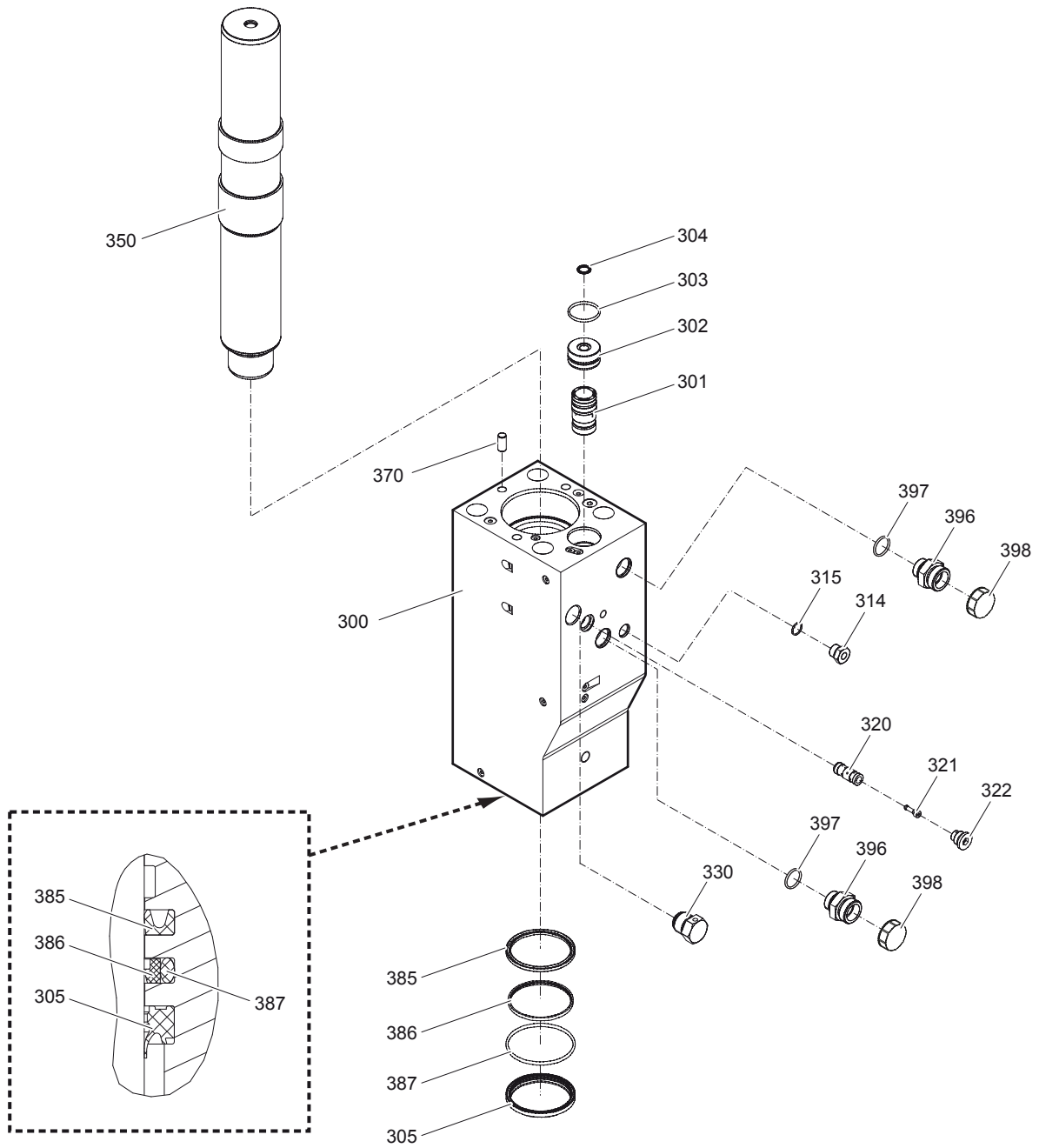

| No. | Description | Remark | Quantity | Part number |
|-----|--------------------|--------------|----------|--------------|
| 300 | Cylinder | | 1 | 3363 0917 05 |
| 301 | Main control valve | | 1 | 3363 0928 81 |
| 302 | Cover | | 1 | 3360 9967 67 |
| 303 | O-ring | | 1 | 3360 3144 94 |
| 304 | Seal | | 1 | 3362 2675 85 |
| 305 | Wiper | | 1 | 3363 0917 14 |
| 314 | Connecting screw | | 1 | 3361 8546 57 |
| 315 | O-ring | | 1 | 3360 4781 71 |
| 320 | Valve bushing | | 1 | 3363 0330 59 |
| 321 | Valve piston | | 1 | 3363 1053 05 |
| 322 | Threaded plug | | 1 | 3363 0337 49 |
| 330 | Non-return valve | | 1 | 3361 8545 11 |
| 350 | Percussion piston | | 1 | 3363 0917 03 |
| 370 | Lock pin | | 1 | 3360 1067 84 |
| 385 | Seal | | 1 | 3363 0917 11 |
| 386 | Seal | | 1 | 3363 0917 13 |
| 387 | O-ring | | 1 | 3363 0917 12 |
| 396 | Fitting | with no. 397 | 2 | 3360 9956 65 |
| 397 | O-ring | | 2 | 3360 3145 51 |
| 398 | Protective cap | | 2 | 3361 3534 88 |

Percussion unit part 3: lower breaker part

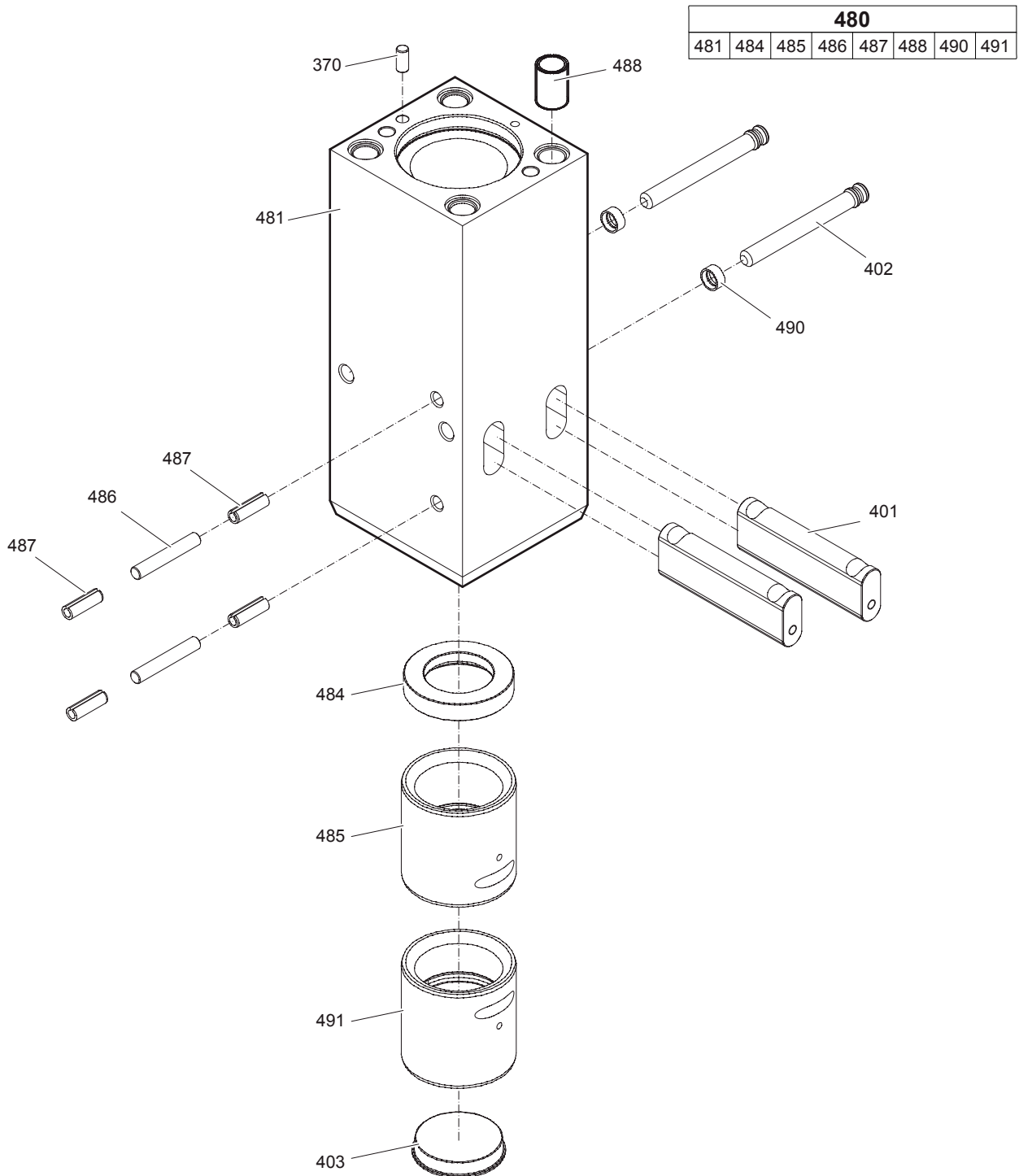

| No. | Description | Remark | Quantity | Part number |
|---------------------|------------------------------------|--|----------|--------------|
| 370 | Lock pin | | 1 | 3360 1067 84 |
| 401 | Retainer bar | | 2 | 3363 1047 79 |
| 402 | Bolt | | 2 | 3363 1047 81 |
| 403 | Protective cap | | 1 | 3363 0317 13 |
| 480(481-491) | Lower breaker part complete | Note: When ordering a lower breaker part for DustProtector version it is imperative to order additionally the base for wiper (no. 18) and the wiper (no. 19). | 1 | 3363 1032 42 |
| 481 | Lower breaker part | | 1 | - |
| 484 | Impact ring | | 1 | 3363 0928 89 |
| 485 | Wear bush | | 1 | 3363 0928 91 |
| 486 | Pin | | 2 | 3362 2615 09 |
| 487 | Spring dowel sleeve | | 4 | 3363 0912 01 |
| 488 | Threaded insert | | 4 | 3363 0894 19 |
| 490 | Locking bush | | 2 | 3363 0330 43 |
| 491 | Wear bush | steel bronze see chapter <i>Optional parts</i> | 1 | 3363 1047 77 |

Connecting kit for ContiLube® II

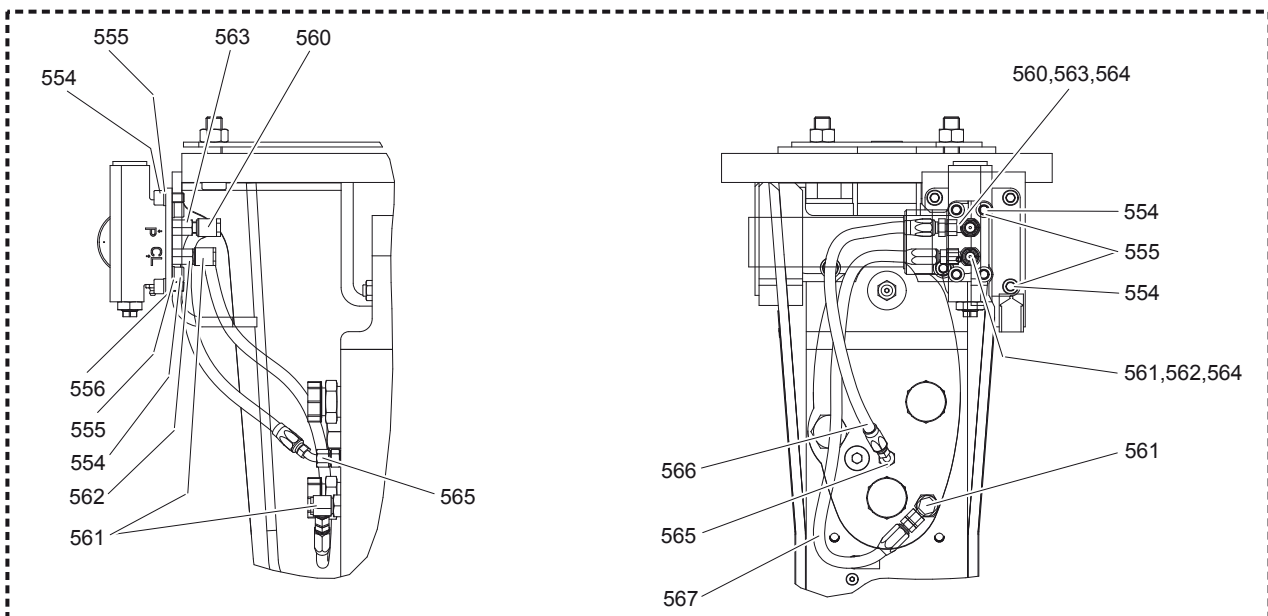
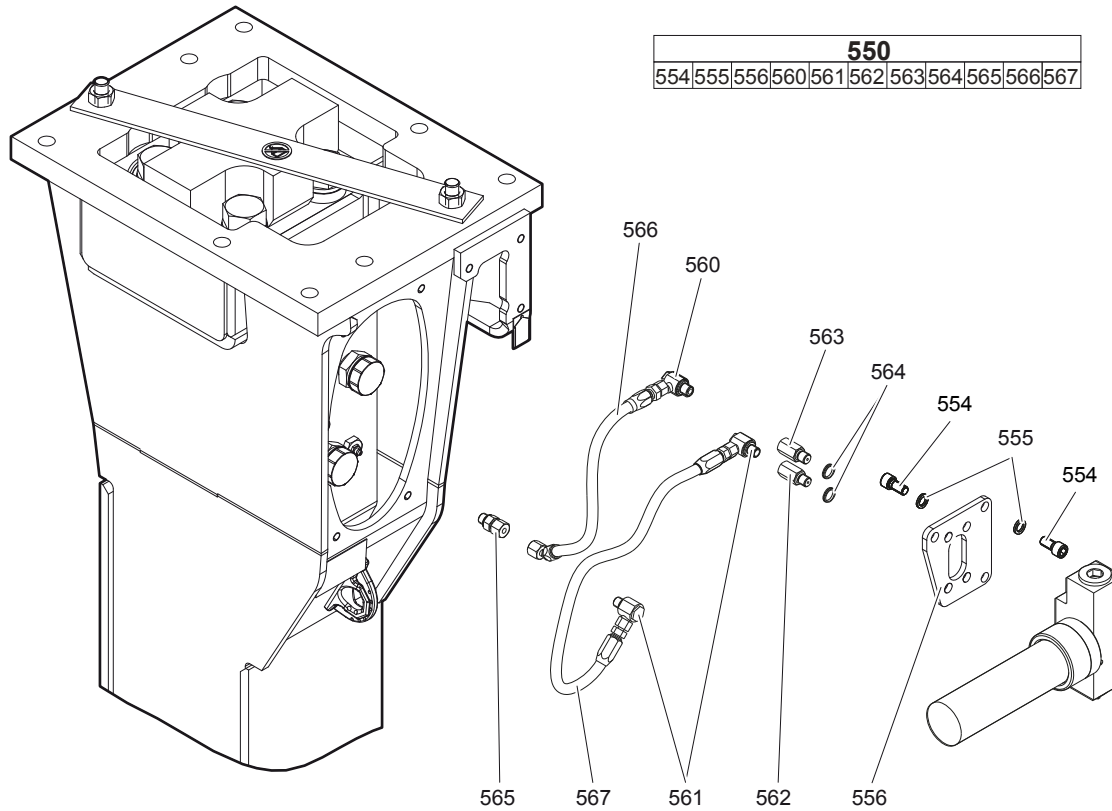

| No. | Description | Remark | Quantity | Part number |
|---------------------|-----------------------|--|----------|--------------|
| 550(554-567) | Connecting kit | | 1 | 3363 0914 76 |
| 554 | Allen screw | secure all 4 allen screws with Loctite 243 screwed in the ContiLube® II | 7 | 3360 1037 50 |
| 555 | Pair of lock washers | | 7 | 3361 8505 96 |
| 556 | Support | | 1 | 3363 0988 10 |
| 560 | Fitting | secure with Loctite 243 | 1 | 3363 0662 34 |
| 561 | Fitting | secure with Loctite 243 | 2 | 3363 0662 33 |
| 562 | Adapter | secure with Loctite 243 | 1 | 3363 0668 87 |
| 563 | Adapter | secure with Loctite 243 | 1 | 3363 0687 45 |
| 564 | Seal | | 2 | 3363 0669 51 |
| 565 | Fitting | secure with Loctite 243 | 1 | 3363 0662 27 |
| 566 | Hydraulic hose | Oil line secure with Loctite 243 Route the hydraulic hoses as shown on the drawing. It must be ensured that the hydraulic hoses can move freely and are not in contact at any point. | 1 | 3363 0913 63 |
| 567 | Hydraulic hose | Grease line secure with Loctite 243 Route the hydraulic hoses as shown on the drawing. It must be ensured that the hydraulic hoses can move freely and are not in contact at any point. | 1 | 3363 0875 83 |

Optional parts

| No. | Description | Remark | Quantity | Part number |
|-----|---------------|--------|----------|--------------|
| 11 | Floating ring | steel | 1 | 3363 0352 09 |
| 491 | Wear bush | bronze | 1 | 3363 1043 69 |

Tightening torques

| No. | Description | Tightening torque | Remark |
|-----|----------------------------|-------------------|---|
| 181 | Filling valve | 130 Nm | Socket spanner size 22 |
| 182 | Threaded plug | 20 Nm | Allen key size 5 |
| 191 | Tensioning bolt | | Torque wrench or Power wrench size 50 1. Pretighten the tensioning bolts to 200 Nm, proceeding in a crosswise fashion, 2. then tighten each tensioning bolt through 120° (2 sides of hexagonal head) in a crosswise fashion, 3. finally tighten each tensioning bolt again through 90° (1 1/2 sides of hexagonal head) in a crosswise fashion. |
| 314 | Threaded plug | 300 Nm | Allen key size 22 |
| 322 | Threaded plug | 100 Nm | Allen key size 12 |
| 330 | Non-return valve | 200 Nm | Socket spanner size 41 |
| 396 | Fitting | 330 Nm | Jaw spanner size 46/50 |
| 554 | Allen screw | 85 Nm | Allen key size 10 |
| 560 | Fitting | 55 Nm | Open-ended wrench size 19, 22 |
| 561 | Fitting | 45 Nm | Open-ended wrench size 17, 19, 22 |
| 562 | Adapter | 45 Nm | Open-ended wrench size 19 |
| 563 | Adapter | 55 Nm | Open-ended wrench size 19 |
| 565 | Fitting | 40 Nm | Open-ended wrench size 19 |
| 566 | Hydraulic hose oil line | 42 Nm | Open-ended wrench size 19 |
| 567 | Hydraulic hose grease line | 16 Nm | Open-ended wrench size 17 |

Working tools

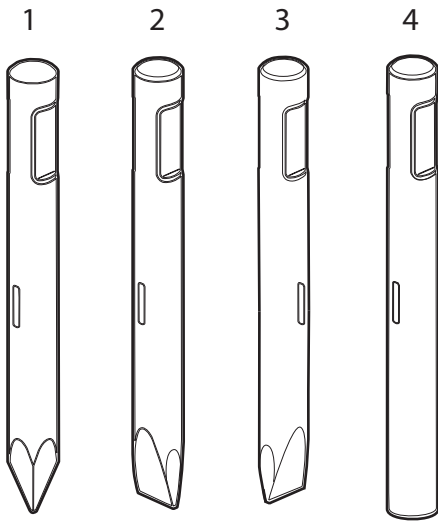

MB 750

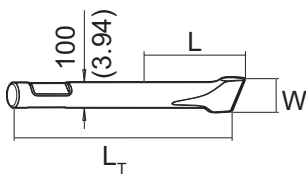

Metric

| No. | Description | Remark | W (mm) | L (mm) | L _T (mm) | Wt (kg) | Part number |
|-----|-------------------|-------------|--------|--------|---------------------|---------|--------------|
| 1 | Moil point | ClassicLine | | 550 | 1000 | 56.0 | 3363 1032 45 |
| 1 | Moil point | SilverLine | | 550 | 1000 | 56.0 | 3363 1034 80 |
| 2 | Chisel (cross) | ClassicLine | 100 | 550 | 1000 | 57.0 | 3363 1032 46 |
| 2 | Chisel (cross) | SilverLine | 100 | 550 | 1000 | 57.0 | 3363 1034 81 |
| 3 | Chisel (parallel) | ClassicLine | 100 | 550 | 1000 | 57.0 | 3363 1032 47 |
| 4 | Blunt tool | ClassicLine | | 550 | 1000 | 60.0 | 3363 1047 85 |
| 4 | Blunt tool | SilverLine | | 550 | 1000 | 60.0 | 3363 1034 82 |

Imperial

| No. | Description | Remark | W (in.) | L (in.) | L _T (in.) | Wt (lb) | Part number |
|-----|-------------------|-------------|---------|---------|----------------------|---------|--------------|
| 1 | Moil point | ClassicLine | | 21.65 | 39.37 | 123.5 | 3363 1032 45 |
| 1 | Moil point | SilverLine | | 21.65 | 39.37 | 123.5 | 3363 1034 80 |
| 2 | Chisel (cross) | ClassicLine | 3.94 | 21.65 | 39.37 | 125.7 | 3363 1032 46 |
| 2 | Chisel (cross) | SilverLine | 3.94 | 21.65 | 39.37 | 125.7 | 3363 1034 81 |
| 3 | Chisel (parallel) | ClassicLine | 3.94 | 21.65 | 39.37 | 125.7 | 3363 1032 47 |
| 4 | Blunt tool | ClassicLine | | 21.65 | 39.37 | 132.3 | 3363 1047 85 |
| 4 | Blunt tool | SilverLine | | 21.65 | 39.37 | 132.3 | 3363 1034 82 |

MB 750 DustProtector

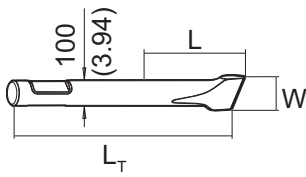

Metric

| No. | Description | Remark | W (mm) | L (mm) | L _T (mm) | Wt (kg) | Part number |
|-----|-------------------|-------------|--------|--------|---------------------|---------|--------------|
| 1 | Moil point | ClassicLine | | 510 | 1000 | 56.0 | 3363 1032 45 |
| 1 | Moil point | SilverLine | | 510 | 1000 | 56.0 | 3363 1034 80 |
| 2 | Chisel (cross) | ClassicLine | 100 | 510 | 1000 | 57.0 | 3363 1032 46 |
| 2 | Chisel (cross) | SilverLine | 100 | 510 | 1000 | 57.0 | 3363 1034 81 |
| 3 | Chisel (parallel) | ClassicLine | 100 | 510 | 1000 | 57.0 | 3363 1032 47 |
| 4 | Blunt tool | ClassicLine | | 510 | 1000 | 60.0 | 3363 1047 85 |
| 4 | Blunt tool | SilverLine | | 510 | 1000 | 60.0 | 3363 1034 82 |

Imperial

| No. | Description | Remark | W (mm) | L (mm) | L _T (mm) | Wt (kg) | Part number |
|-----|-------------------|-------------|--------|--------|---------------------|---------|--------------|
| 1 | Moil point | ClassicLine | | 20.08 | 39.37 | 123.5 | 3363 1032 45 |
| 1 | Moil point | SilverLine | | 20.08 | 39.37 | 123.5 | 3363 1034 80 |
| 2 | Chisel (cross) | ClassicLine | 3.94 | 20.08 | 39.37 | 125.7 | 3363 1032 46 |
| 2 | Chisel (cross) | SilverLine | 3.94 | 20.08 | 39.37 | 125.7 | 3363 1034 81 |
| 3 | Chisel (parallel) | ClassicLine | 3.94 | 20.08 | 39.37 | 125.7 | 3363 1032 47 |
| 4 | Blunt tool | ClassicLine | | 20.08 | 39.37 | 132.3 | 3363 1047 85 |
| 4 | Blunt tool | SilverLine | | 20.08 | 39.37 | 132.3 | 3363 1034 82 |

Accessories

Hydraulic hoses

| Description | Remark | Quantity | Part number |
|-------------|---|----------|--------------|
| Hose | I.D. 25 (1"), both ends M 42x2 conical seal 24°, length 2300 mm (91 in.) | 2 | 3360 9923 40 |
| Hose | I.D. 25 (1"), both ends M 42x2 conical seal 24°, length 2800 mm (110 in.) | 2 | 3361 8538 59 |

Optional equipment

| Description | Remark | Quantity | Part number |
|--|-------------------------------|----------|--------------|
| Chisel paste cartridge for ContiLube® II | 12 x 500 g (1.1 lbs) | 1 | 3363 0912 00 |
| Grease gun for cartridge ContiLube® II | | 1 | 3363 0345 67 |
| Grease nipple | | 1 | 3360 4337 74 |
| Service box no. I with nitrogen cylinder | 2 l 0.43 gal (0.53 US gal) | 1 | 3363 0898 44 |
| Service box no. III without nitrogen cylinder | | 1 | 3363 0949 40 |
| Test gauge lower wear bush | | 1 | 3362 2352 93 |
| Inside calliper upper wear bush | | 1 | 3363 0949 52 |
| Adapter plate matching the carrier Consult the Atlas Copco Customer Center/Dealer in your area. | | 1 | - |
| Base plate with threaded inserts | | 1 | 3363 0997 97 |
| Bolt kit | | 1 | 3363 0945 37 |
| Base plate with through borings | | 1 | 3363 1006 95 |
| Bolt kit | | 1 | 3363 0945 74 |
| Allen key | 19 mm for bolt kit | 1 | 3360 2092 53 |
| Adapter kit for underwater applications | | 1 | 3363 0905 31 |
| Piston retainer | | 1 | 3363 0929 71 |

Kits

Label kit MB 750

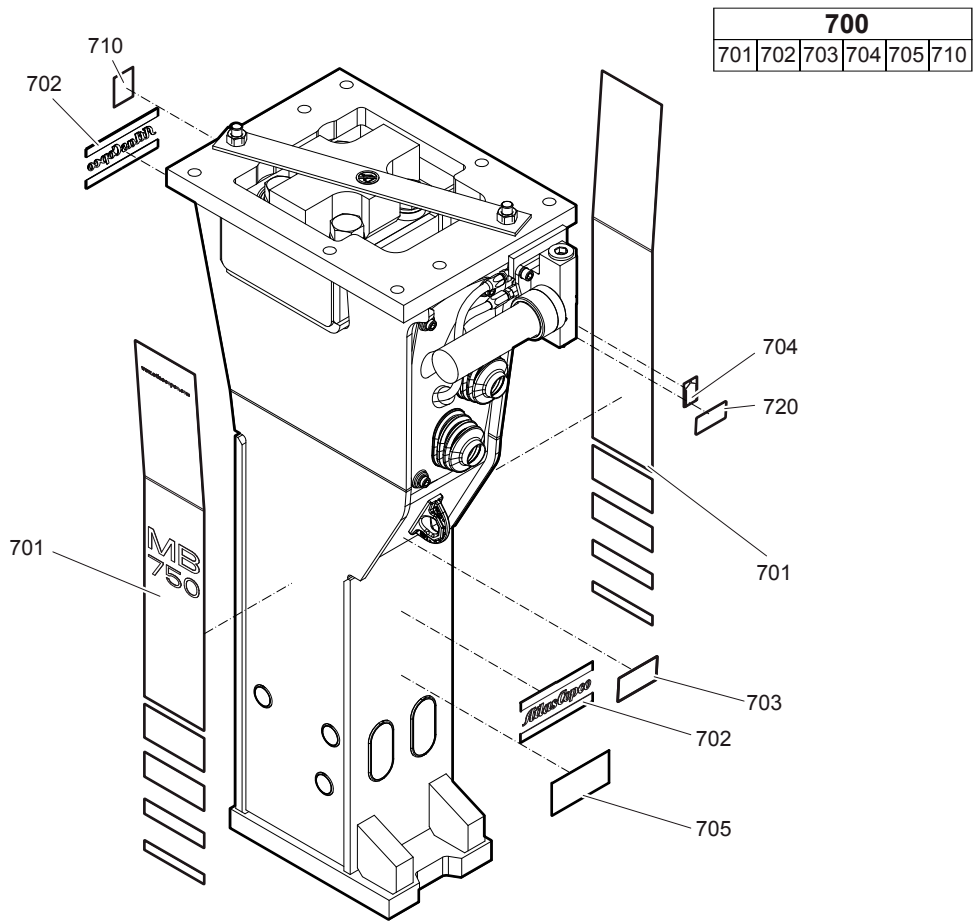

| No. | Description | Remark | Quantity | Part number |
|---------------------|-------------------------|--|----------|--------------|
| 700(701-710) | Label kit MB 750 | | 1 | 3363 1034 73 |
| 701 | Product label | "MB 750" | 2 | - |
| 702 | Product label | "Atlas Copco" | 2 | - |
| 703 | Label gas pressure | | 2 | - |
| 704 | Lubricating symbol | | 1 | - |
| 705 | Label working tools | | 1 | - |
| 710 | Sound power label | | 1 | - |
| 720 | Name plate | Consult the Atlas Copco Customer Center/Dealer in your area. | 1 | - |

Label kit MB 750 DustProtector

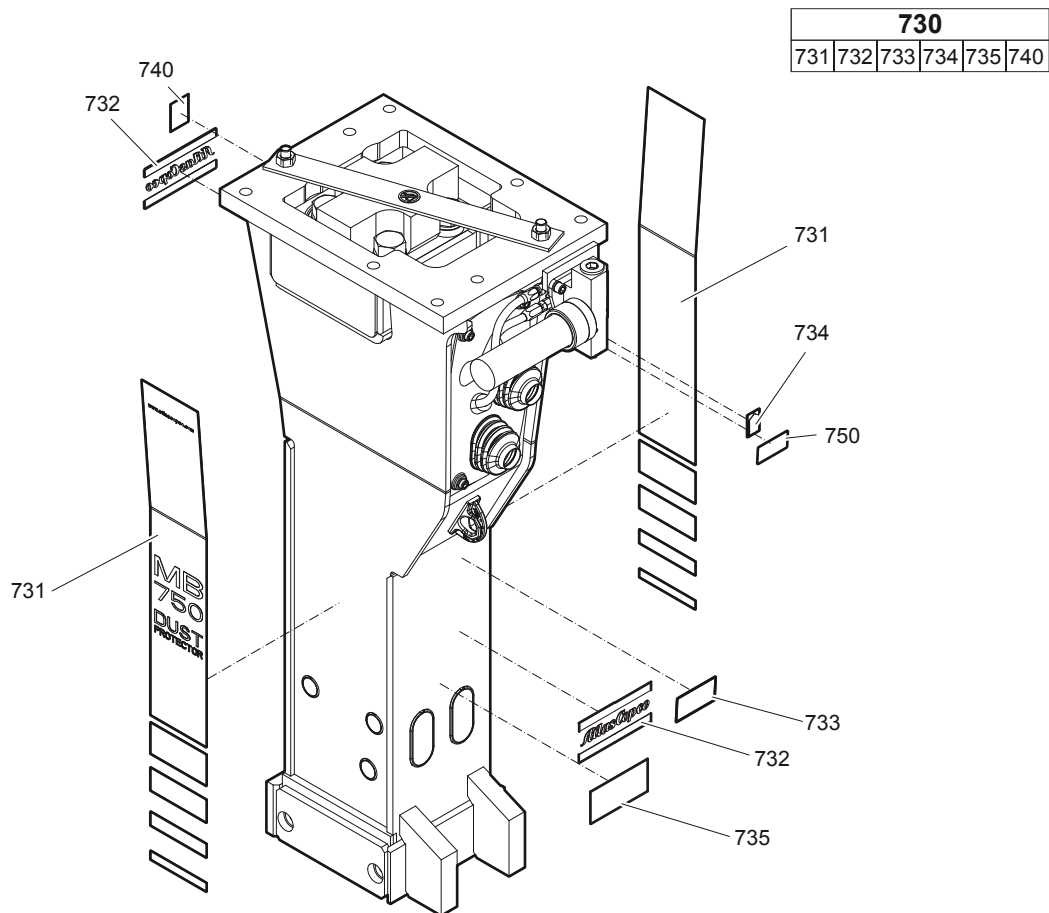

| No. | Description | Remark | Quantity | Part number |
|---------------------|----------------------------|--|----------|--------------|
| 730(731-740) | Label kit MB 750 DP | | 1 | 3363 1034 74 |
| 731 | Product label | "MB 750 DP" | 2 | - |
| 732 | Product label | "Atlas Copco" | 2 | - |
| 733 | Label gas pressure | | 2 | - |
| 734 | Lubricating symbol | | 1 | - |
| 735 | Label working tools | | 1 | - |
| 740 | Sound power label | | 1 | - |
| 750 | Name plate | Consult the Atlas Copco Customer Center/Dealer in your area. | 1 | - |

Seal kit

| No. | Description | Remark | Quantity | Part number |
|-----|-----------------|--------|----------|--------------|
| | Seal kit | | 1 | 3363 0917 07 |
| 120 | O-ring | | 1 | 3360 3146 64 |
| 122 | Seal | | 1 | 3363 0917 10 |
| 123 | Seal | | 2 | 3363 0917 08 |
| 124 | O-ring | | 2 | 3363 0917 09 |
| 182 | Threaded plug | | 1 | 3360 4784 26 |
| 183 | O-ring | | 1 | 3360 1751 25 |
| 303 | O-ring | | 1 | 3360 3144 94 |
| 304 | Seal | | 1 | 3362 2675 85 |
| 305 | Wiper | | 1 | 3363 0917 14 |
| 315 | O-ring | | 1 | 3360 4781 71 |
| 385 | Seal | | 1 | 3363 0917 11 |
| 386 | Seal | | 1 | 3363 0917 13 |
| 387 | O-ring | | 1 | 3363 0917 12 |
| 397 | O-ring | | 2 | 3360 3145 51 |

Plastic parts kit

| No. | Description | Remark | Quantity | Part number |
|-----|--------------------------|--------|----------|--------------|
| | Plastic parts kit | | 1 | 3363 1034 72 |
| 2 | Elastic pad | | 1 | 3363 0928 57 |
| 3 | Shock absorber | | 2 | 3361 8522 37 |
| 5 | Guide plate | | 2 | 3363 1007 37 |
| 6 | Guide plate | | 1 | 3363 0842 31 |
| 7 | Guide plate | | 2 | 3363 0928 61 |

Tensioning bolt kit

| No. | Description | Remark | Quantity | Part number |
|-----|----------------------------|--------|----------|--------------|
| | Tensioning bolt kit | | 1 | 3363 0943 45 |
| 191 | Tensioning bolt | | 2 | 3363 0928 73 |
| 192 | Washer | | 2 | 3363 0936 45 |
| 488 | Threaded insert | | 2 | 3363 0894 19 |
| | Anti Seize 120 g | | 1 | 3363 0943 00 |

DustProtector kit

| No. | Description | Remark | Quantity | Part number |
|-----|--------------------------|----------|----------|--------------|
| | DustProtector kit | | 1 | 3363 0943 83 |
| 11 | Floating ring | tribolid | 1 | 3363 0706 58 |
| 12 | Counter ring | | 1 | 3363 0352 07 |
| 13 | Guide ring | | 1 | 3363 0352 05 |
| 14 | Bolt | | 2 | 3363 0913 65 |
| 15 | Locking bush | | 2 | 3361 8543 63 |

Noise protection kit

| No. | Description | Remark | Quantity | Part number |
|-----|-----------------------------|--------|----------|--------------|
| | Noise protection kit | | 1 | 3363 1034 76 |
| 31 | Cover | | 1 | 3363 0928 63 |
| 32 | Plug | | 2 | 3363 0860 11 |
| 33 | Plug | | 10 | 3362 2678 97 |
| 34 | Allen screw | | 4 | 3360 1007 91 |
| 35 | Pair of lock washers | | 4 | 3361 8505 96 |

Lower breaker part kit

| No. | Description | Remark | Quantity | Part number |
|-----|-------------------------------|--------|----------|--------------|
| | Lower breaker part kit | | 1 | 3363 1034 84 |
| 401 | Retainer bar | | 2 | 3363 1047 79 |
| 402 | Bolt | | 2 | 3363 1047 81 |
| 484 | Impact ring | | 1 | 3363 0928 89 |
| 485 | Wear bush | | 1 | 3363 0928 91 |
| 486 | Pin | | 2 | 3362 2615 09 |
| 487 | Spring dowel sleeve | | 4 | 3363 0912 01 |
| 490 | Locking bush | | 2 | 3363 0330 43 |
| 491 | Wear bush | steel | 1 | 3363 1047 77 |
| | Chisel paste | | 1 | 3315 0381 00 |
| | Test gauge | | 1 | 3362 2352 93 |

Lower breaker part kit DustProtector

| No. | Description | Remark | Quantity | Part number |
|-----|-------------------------------|--------|----------|--------------|
| | Lower breaker part kit | | 1 | 3363 1034 75 |
| 18 | Base for wiper | | 1 | 3363 1047 83 |
| 19 | Wiper | | 1 | 3363 0343 94 |
| 401 | Retainer bar | | 2 | 3363 1047 79 |
| 402 | Bolt | | 2 | 3363 1047 81 |
| 484 | Impact ring | | 1 | 3363 0928 89 |
| 485 | Wear bush | | 1 | 3363 0928 91 |
| 486 | Pin | | 2 | 3362 2615 09 |
| 487 | Spring dowel sleeve | | 4 | 3363 0912 01 |
| 490 | Locking bush | | 2 | 3363 0330 43 |
| 491 | Wear bush | steel | 1 | 3363 1047 77 |
| | Chisel paste | | 1 | 3315 0381 00 |
| | Test gauge | | 1 | 3362 2352 93 |

Dimensions

Dimensions MB 750

mm (inch)

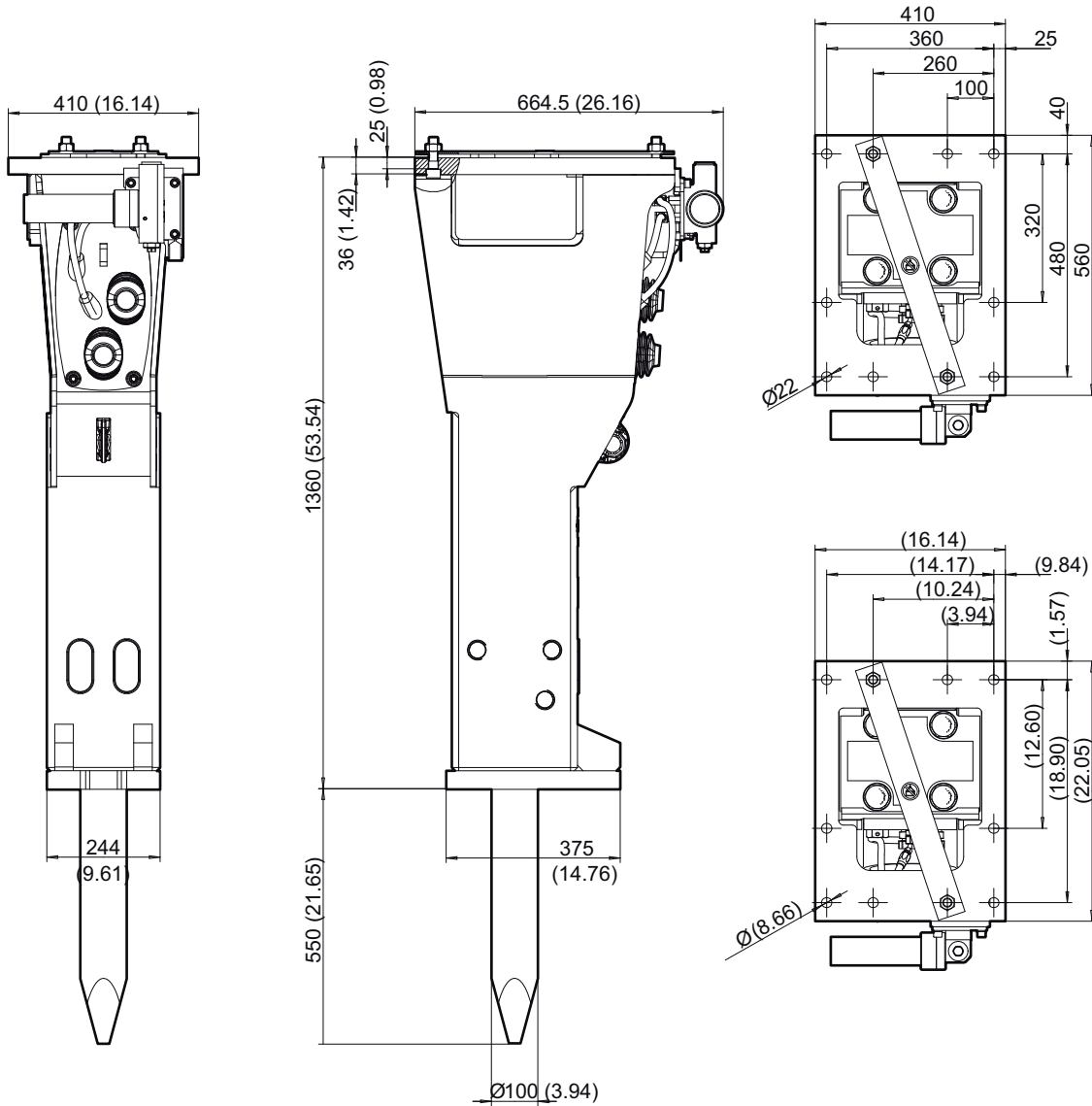

Dimensions MB 750 DustProtector

mm (inch)

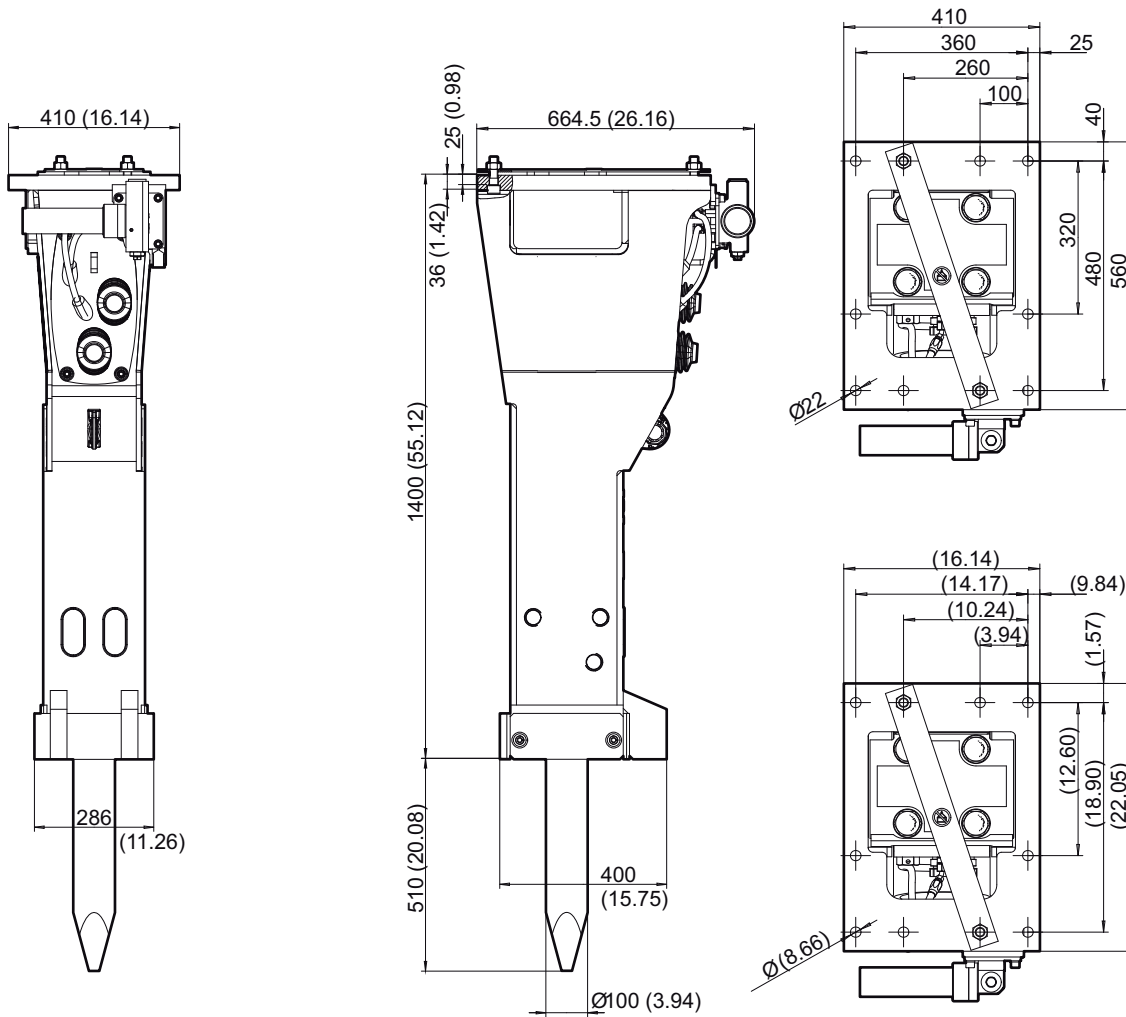



Any unauthorized use or copying of the contents or any part thereof is prohibited.
This applies in particular to trademarks, model denominations, part numbers, and drawings.

© 2013 Atlas Copco Construction Tools GmbH | No. 3390 7402 01 | 2013-05-02